



3.2Gbps Adaptive Equalizer and Cable Driver

MAX3800

General Description

The MAX3800 is a +3.3V adaptive cable equalizer and cable driver implemented together on a single chip. It is designed for coaxial and twin-axial cable point-to-point communications applications. The driver features differential current-mode logic (CML) inputs and outputs as well as adjustable output amplitude. The equalizer includes differential CML data inputs and outputs, a loss-of-signal (LOS) output, and a cable integrity monitor (CIM) output.

The adaptive cable equalizer is capable of equalizing differential or single-ended signals at data rates up to 3.2Gbps. It automatically adjusts to attenuation caused by skin-effect losses of up to 30dB at 1.6GHz. The equalizer effectively extends the usable length of copper cable in high-frequency interconnect applications.

The MAX3800 is available in a 32-pin TQFP package with exposed pad and consumes only 200mW at +3.3V. The driver can be disconnected from the power supply when it is not needed, resulting in a 40% reduction in supply current.

Applications

High-Speed Links in Communications and Data Systems
Backplane and Interconnect Applications
SDH/SONET Transmission Equipment

Pin Configuration appears at end of data sheet.

Features

- ◆ Single +3.3V Operation
- ◆ Typical Power Dissipation = 200mW at +3.3V
- ◆ Data Rates Up to 3.2Gbps
- ◆ Adjustable Cable Driver Output Amplitude
- ◆ Equalizer Automatically Adjusts for Different Cable Lengths
- ◆ 0dB to 30dB Equalization at 1.6GHz (3.2Gbps)
- ◆ Loss-of-Signal ($\overline{\text{LOS}}$) Indicator
- ◆ Cable Integrity Monitor (CIM)
- ◆ On-Chip Input and Output Terminations
- ◆ Low External Component Count
- ◆ Operating Temperature Range = 0°C to +85°C
- ◆ ESD Protection on Cable Inputs and Outputs

Ordering Information

PART	TEMP RANGE	PIN-PACKAGE	PKG CODE
MAX3800UGJ	0°C to +85°C	32 QFN	G3255-1
MAX3800UHJ	0°C to +85°C	32 TQFP-EP*	AA-EP
MAX3800UHJ+	0°C to +85°C	32 TQFP-EP*	AA-EP

*EP = exposed pad

+Denotes lead-free package.

Typical Application Circuit

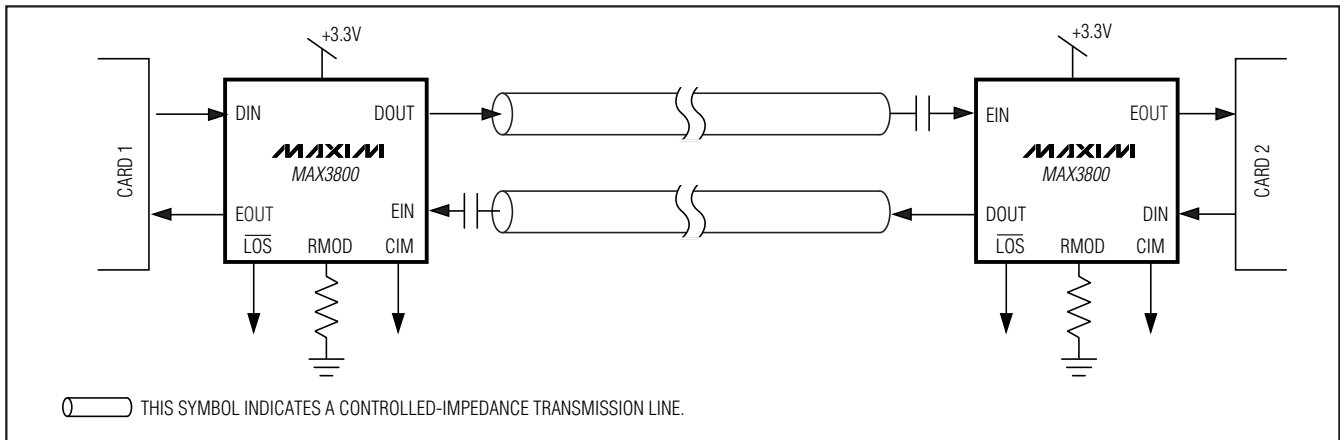

3.2Gbps Adaptive Equalizer and Cable Driver

ABSOLUTE MAXIMUM RATINGS

Supply Voltage, V_{CC}-0.5V to +6.0V
 Voltage at LOS, RMOD, and CIM.....-0.5V to ($V_{CC} + 0.5V$)
 Voltage at EIN+, EIN-, DIN+, DIN-($V_{CC} - 1V$) to ($V_{CC} + 0.5V$)
 Current Out of EOUT+, EOUT-, DOUT+, DOUT-25mA
 Continuous Power Dissipation ($T_A = +85^\circ C$)
 32-Pin TQFP-EP (derate 22.2mW/ $^\circ C$ above +85 $^\circ C$) ...1444mW

Operating Ambient Temperature Range0 $^\circ C$ to +85 $^\circ C$
 Storage Temperature Range-55 $^\circ C$ to +150 $^\circ C$
 Lead Temperature (soldering, 10s)+300 $^\circ C$

Stresses beyond those listed under "Absolute Maximum Ratings" may cause permanent damage to the device. These are stress ratings only, and functional operation of the device at these or any other conditions beyond those indicated in the operational sections of the specifications is not implied. Exposure to absolute maximum rating conditions for extended periods may affect device reliability.

DC ELECTRICAL CHARACTERISTICS

($V_{CC} = +3.14V$ to +3.46V, $T_A = 0^\circ C$ to +85 $^\circ C$. Typical values are at $V_{CC} = +3.3V$ and $T_A = +25^\circ C$, unless otherwise noted.)

PARAMETER	SYMBOL	CONDITIONS	MIN	TYP	MAX	UNITS
Supply Current	I_{CC}	Includes external load current (Note 1)		65	85	mA
CABLE DRIVER INPUT SPECIFICATIONS						
Input Voltage (Single-Ended)	V_{DIN+} , V_{DIN-}		$V_{CC} - 0.6$		$V_{CC} + 0.2$	V
Input Voltage (Differential)	V_{DIN}	$V_{DIN} = (V_{DIN+}) - (V_{DIN-})$	400		1100	mVp-p
Input Impedance		Single-ended	45	55	65	Ω
CABLE DRIVER OUTPUT SPECIFICATIONS						
Output Voltage (Differential)		$R_{MOD} = 10k\Omega$ (Note 2)	750	870	1000	mVp-p
		$R_{MOD} = 20k\Omega$ (Note 2)	400	450	550	mVp-p
Output Impedance		Single-ended	50	62.5	75	Ω
CABLE EQUALIZER INPUT SPECIFICATIONS						
Minimum Cable Input (Differential)		3.2Gbps, 30dB cable loss at 1.6GHz (Note 3)		650	700	mVp-p
Maximum Cable Input (Differential)				1100		mVp-p
Input Impedance		Single-ended	45	55	65	Ω
CABLE EQUALIZER OUTPUT SPECIFICATIONS						
Output Voltage (Differential)		(Note 2)	500		1000	mVp-p
Output Impedance		Single-ended	50	62.5	75	Ω
Voltage at CIM Output (Differential)	V_{CIM}	No external load, $V_{CIM} = (V_{CIM+}) - (V_{CIM-})$	-0.5		+0.5	Vp-p
Voltage at CIM Output (Single-Ended)	V_{CIM+} , V_{CIM-}	No external load	0.5		$V_{CC} - 0.5$	V
Voltage at \overline{LOS}		Output high (Note 4)	2.4			V
		Output low (Note 4)			0.4	V
Output Common-Mode Voltage		Each output DC-coupled 50 Ω to V_{CC}		$V_{CC} - 0.2$		V

3.2Gbps Adaptive Equalizer and Cable Driver

MAX3800

AC ELECTRICAL CHARACTERISTICS

($V_{CC} = +3.14V$ to $+3.46V$, $T_A = 0^{\circ}C$ to $+85^{\circ}C$. Typical values are at $V_{CC} = +3.3V$ and $T_A = +25^{\circ}C$, unless otherwise noted.) (Note 5)

PARAMETER	SYMBOL	CONDITIONS	MIN	TYP	MAX	UNITS
Maximum Input Data Rate			3.2			Gbps
CABLE DRIVER SPECIFICATIONS						
Random Jitter		(Note 6)		2	4	mUI _{RMS}
Deterministic Jitter		(Note 6)		20	60	mUI _{p-p}
Output Edge Speed		20% to 80%		59	76	ps
Input Return Loss (Single-Ended)		$\leq 3.2GHz$		14		dB
Output Return Loss (Single-Ended)		$\leq 3.2GHz$		14		dB
EQUALIZER SPECIFICATIONS						
Residual Jitter (Note 7)		0dB cable loss (Note 8)		170	240	mUI _{p-p}
		24dB cable loss (Note 8)		97	200	mUI _{p-p}
		30dB cable loss (Note 8)		112	200	mUI _{p-p}
Output Edge Speed		20% to 80%		56	77	ps
Input Return Loss (Single-Ended)		$\leq 3.2GHz$		14		dB
Output Return Loss (Single-Ended)		$\leq 3.2GHz$		14		dB
Equalization Compensation		1.6GHz (skin-effect losses only)	30			dB
Equalization Time Constant				5		μs

Note 1: Equalizer and driver total currents (equalizer with maximum equalization and driver with maximum output swing).

Note 2: Input voltage within specification limits, 50Ω to V_{CC} at each output.

Note 3: Minimum cable input for \overline{LOS} to assert high.

Note 4: $100k\Omega$ load to ground.

Note 5: AC electrical characteristics are guaranteed by design and characterization.

Note 6: $V_{DIN} = 400mVp-p$ to $1100mVp-p$ (differential), $10k\Omega \leq R_{MOD} \leq 20k\Omega$, 3.2Gbps $2^{13}-1$ PRBS with 100 consecutive ones and 100 consecutive zeros substituted.

Note 7: Includes random jitter and deterministic jitter.

Note 8: Differential cable input voltage = $700mVp-p$, 3.2Gbps $2^{13}-1$ PRBS with 100 consecutive ones and 100 consecutive zeros substituted. Cable loss is due to skin effect only.

3.2Gbps Adaptive Equalizer and Cable Driver

Typical Operating Characteristics

($T_A = +25^\circ\text{C}$, $V_{CC} = +3.3\text{V}$, all jitter measurements done at 3.2Gbps, 700mV cable input with 2^{13} -1 PRBS pattern with 100 consecutive ones and 100 consecutive zeros substituted. **Note:** Test pattern produces near worst-case jitter results. Results will vary with pattern, unless otherwise noted.)

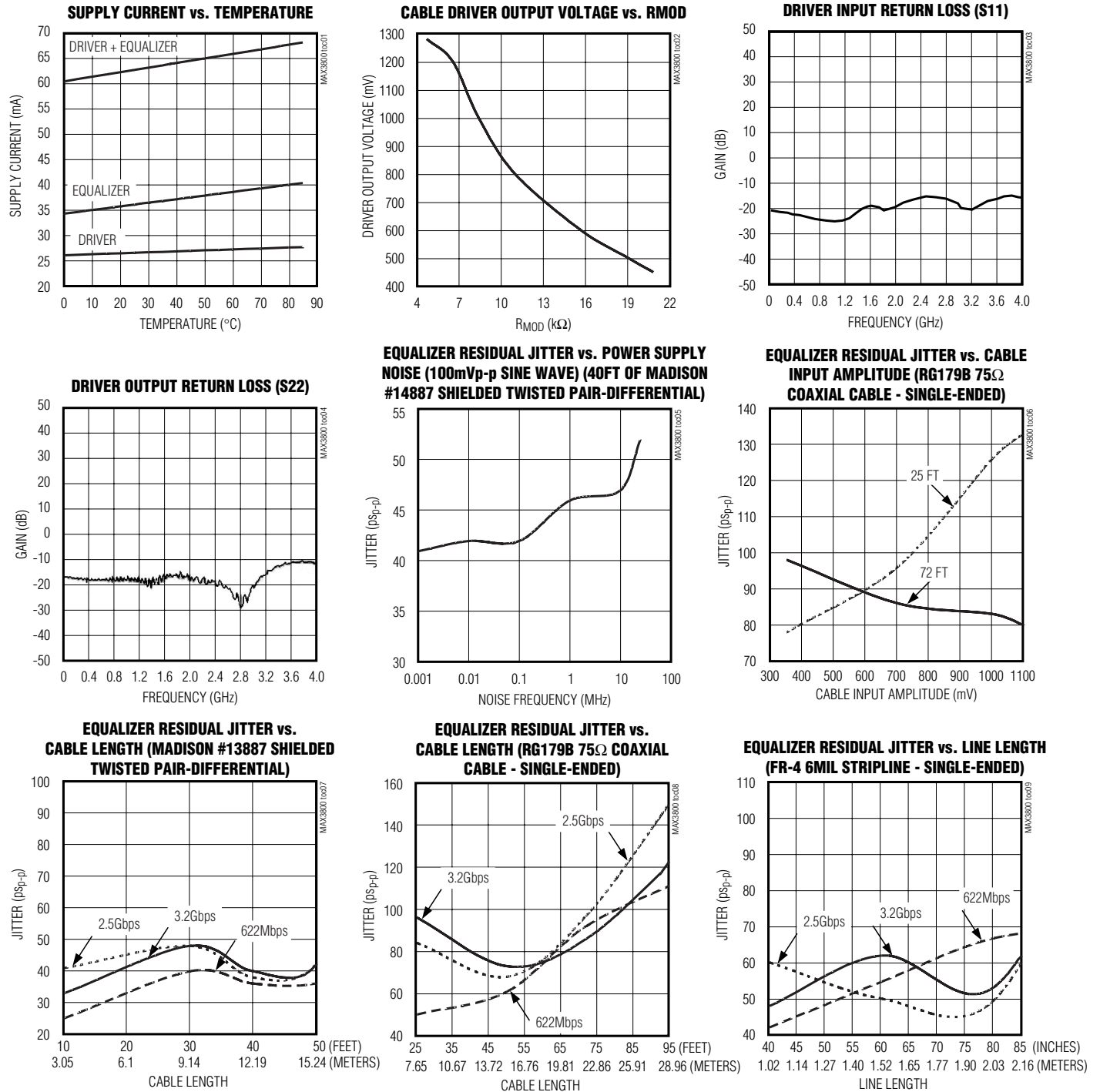

3.2Gbps Adaptive Equalizer and Cable Driver

MAX3800

Typical Operating Characteristics (continued)

($T_A = +25^\circ\text{C}$, $V_{CC} = +3.3\text{V}$, all jitter measurements done at 3.2Gbps, 700mV cable input with $2^{13}-1$ PRBS pattern with 100 consecutive ones and 100 consecutive zeros substituted. **Note:** Test pattern produces near worst-case jitter results. Results will vary with pattern, unless otherwise noted.)

**EQUALIZER INPUT AFTER
115FT OF CABLE (TOP)
EQUALIZER OUTPUT (BOTTOM)**

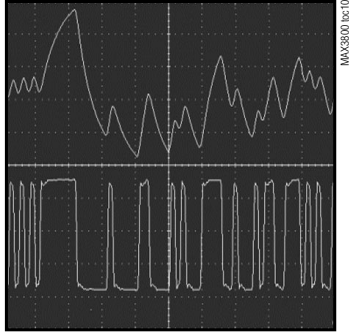

**EQUALIZER OUTPUT EYE DIAGRAM
AFTER 115FT OF 50Ω GORE 89 CABLE
(DIFFERENTIAL, 2^7-1 PRBS)**

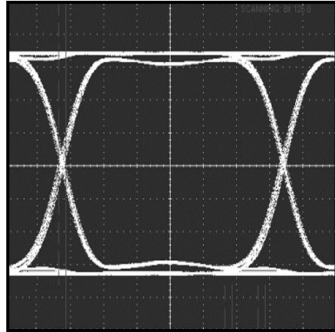

**EQUALIZER OUTPUT EYE DIAGRAM
AFTER 100FT OF 75Ω RG179 CABLE
(SINGLE-ENDED, 2^7-1 PRBS)**

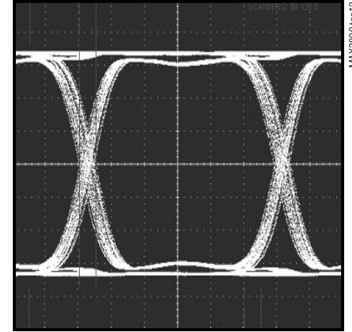

**EQUALIZER OUTPUT EYE DIAGRAM
AFTER 100FT OF BELDEN 9207 CABLE
(DIFFERENTIAL, 2^7-1 PRBS)**

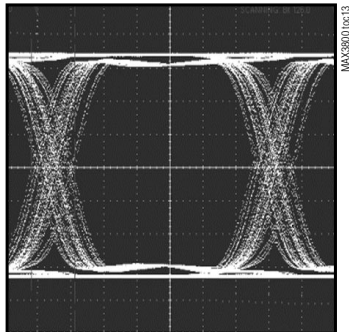

**EQUALIZER OUTPUT EYE DIAGRAM
AFTER 50FT OF MADISON #14887
SHIELDED TWISTED PAIR CABLE
(DIFFERENTIAL, 2^7-1 PRBS)**

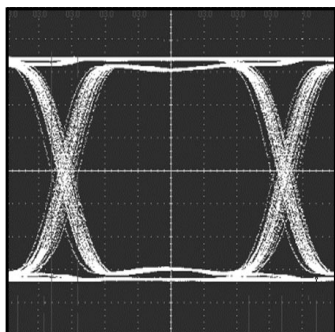

**CIM VOLTAGE vs. CABLE LENGTH
(RG179B 75Ω COAXIAL CABLE -
SINGLE-ENDED)**

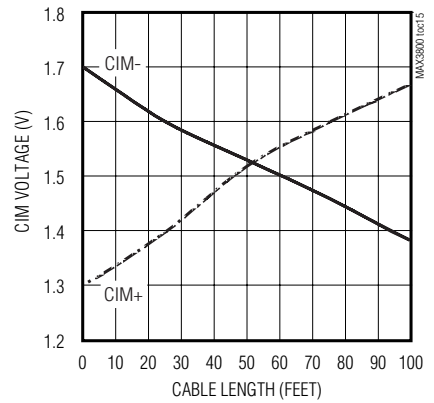

EQUALIZER INPUT RETURN LOSS (S11)

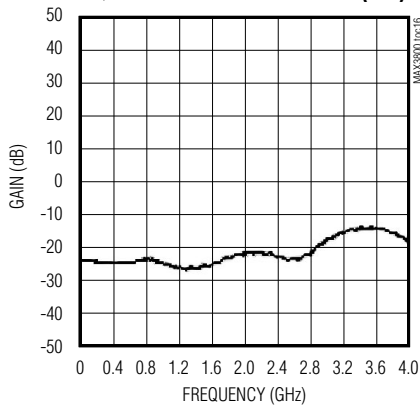

EQUALIZER OUTPUT RETURN LOSS (S22)

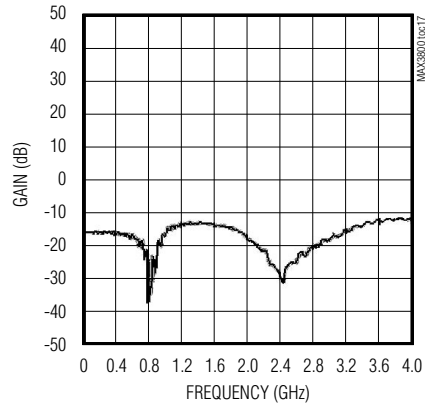

3.2Gbps Adaptive Equalizer and Cable Driver

Pin Description

PIN	NAME	FUNCTION
1, 3, 6, 11, 14	V _{CCE}	Equalizer Power Supply
2, 7, 10, 15, 23, 24, 26, 31	GND	Ground
4	EIN+	Positive Equalizer Input, CML
5	EIN-	Negative Equalizer Input, CML
8	CIM-	Negative Cable Integrity Monitor (CIM) Output
9	CIM+	Positive Cable Integrity Monitor (CIM) Output
12	EOUT-	Negative Equalizer Output, CML
13	EOUT+	Positive Equalizer Output, CML
16, 17	N.C.	No Connection. Leave unconnected.
18	$\overline{\text{LOS}}$	Equalizer Loss-of-Signal Output, Active-Low
19, 22, 27, 30, 32	V _{CCD}	Driver Power Supply
20	DIN+	Positive Driver Input, CML
21	DIN-	Negative Driver Input, CML
25	RMOD	Driver Output Modulation Adjust. A resistor connected from this pin to GND controls driver output voltage.
28	DOUT+	Positive Driver Output, CML
29	DOUT-	Negative Driver Output, CML
EP	Exposed Pad	Ground. The exposed pad must be soldered to the circuit board ground plane for proper thermal and electrical performance.

Detailed Description

The MAX3800 consists of a cable driver (transmitter) and an adaptive cable equalizer (receiver). The driver and equalizer are implemented on the same chip, but they are completely independent.

The Cable Driver

The cable driver accepts differential or single-ended current-mode logic (CML) input data at rates up to 3.2Gbps. The driver output is also implemented using CML. The maximum output amplitude can be adjusted over a typical range of 450mV to 870mV by changing the value of the RMOD resistor between 10k Ω and 20k Ω (this resistor is connected between the RMOD pin and ground).

The Adaptive Cable Equalizer

The adaptive cable equalizer accepts differential CML input data at rates up to 3.2Gbps and is capable of equalizing differential or single-ended signals. It automatically adjusts to attenuation levels of up to 30dB at 1.6GHz (due to skin-effect losses in copper cable). The equalizer consists of a CML input buffer, a loss-of-sig-

nal detector, a flat response amplifier, a skin-effect compensation amplifier, a current-steering network, a dual power-detector feedback loop, an output limiting amplifier, and a CML output buffer (Figure 1).

General Theory of Operation

The shape of the power spectrum of a random bit stream can be described by the square of the sinc function, where $\text{sinc } f = (\sin \pi f) / \pi f$. For sufficiently long bit patterns (nonrandom bit streams), $\text{sinc}^2(f)$ is a good approximation. From the shape of the $\text{sinc}^2(f)$ function, we can estimate the ratio of the power densities at any two frequencies. The MAX3800 adaptive equalizer employs this principle by incorporating a feedback loop that continuously monitors the power at two frequencies and dynamically adjusts the equalizer to maintain the correct power ratio.

CML Input and Output Buffers

The input and output buffers are implemented using current-mode logic (CML). Equivalent circuits are shown in Figures 2 and 3. For details on interfacing with

3.2Gbps Adaptive Equalizer and Cable Driver

MAX3800

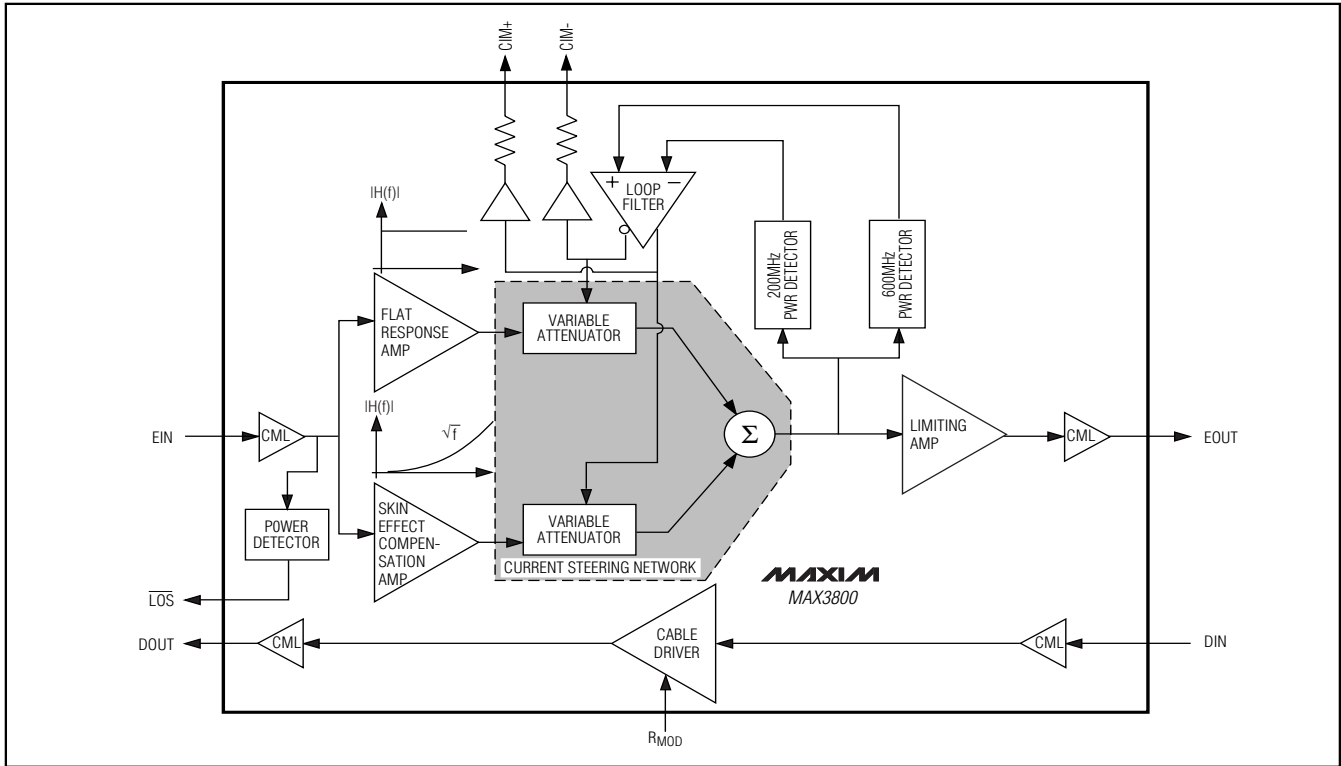

Figure 1. Functional Diagram

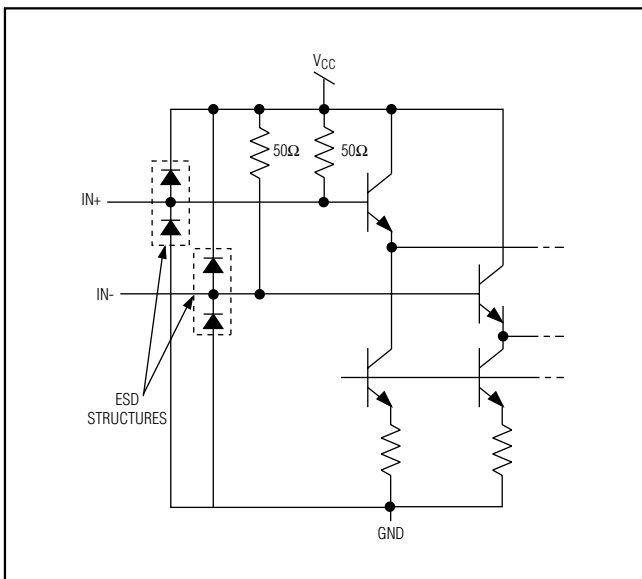

Figure 2. CML Input Equivalent Circuit

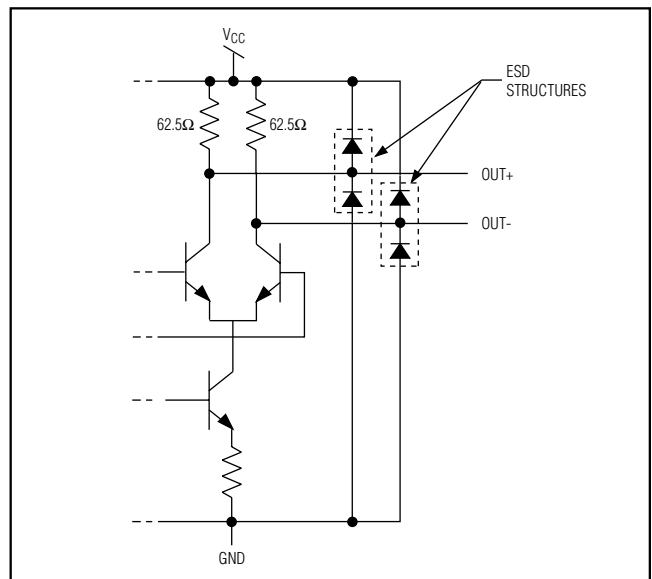

Figure 3. CML Output Equivalent Circuit

3.2Gbps Adaptive Equalizer and Cable Driver

CML, see Maxim application note HFAN-1.0, *Interfacing Between CML, PECL, and LVDS*.

Flat Response and Skin-Effect Compensation Amplifiers

The buffered input waveform is fed equally to two amplifiers—the flat response amplifier and the skin-effect compensation amplifier. The flat response amplifier has a constant gain over the entire frequency range of the device, and the skin-effect compensation amplifier has a gain characteristic that approximates the inverse of the skin-effect attenuation inherent in copper cable. The skin-effect attenuation, in dB per unit length, is proportional to the square root of the frequency. The output currents from the two amplifiers are supplied to the current-steering network. Note that when $\overline{\text{LOS}}$ asserts low, equalization is minimized.

Current-Steering Network

The function of the current-steering network is to combine adjustable quantities of the output currents from the flat response and skin-effect compensation amplifiers to achieve a desired current ratio. The ratio adjustment is controlled by the dual power-detector feedback loop.

The current-steering network is implemented with a pair of variable attenuators that feed into a current-summing node. The variable attenuators are used to attenuate the output currents of the flat response and skin-effect compensation amplifiers under control of the dual power-detector feedback loop. The outputs of the two attenuators are combined at the summing node and then fed to the output limiting amplifier and the feedback loop.

Dual Power-Detector Feedback Loop

The output of the current-steering network is applied to the inputs of two frequency-specific power detectors. One of the power detectors is tuned to 200MHz and the other is tuned to 600MHz. The outputs of the two power detectors are applied to the inverting (200MHz power detector) and noninverting (600MHz power detector) inputs of the differential loop amplifier. The differential outputs of the loop amplifier control the variable attenuators in the current-steering network.

Output Limiting Amplifier

The output limiting amplifier amplifies the signal from the current-steering network to achieve the specified output voltage swing.

Applications Information

Refer to Maxim application note HFDN-10.0, *Equalizing Gigabit Copper Cable Links with the MAX3800* (available at www.maxim-ic.com) for additional applications information.

Selecting RMOD

The cable driver output amplitude can be adjusted by connecting a resistor with a value from 10k Ω to 20k Ω between the RMOD pin and ground. The exact output amplitude of the driver for a given value of RMOD resistance is dependent on a number of factors. Refer to the *Typical Operating Characteristics* “Cable Driver Output Voltage vs. RMOD” for typical values.

Cable Integrity Monitor (CIM)

The differential CIM output current is directly proportional to the output current of the loop amplifier (which controls the current-steering network—see *Detailed Description*). This is an analog current output that indicates the amount of equalization that is being applied. A convenient way to monitor the CIM current is to connect a 100k Ω resistor from each of the CIM outputs to ground, and then measure the voltage at the CIM pins.

The amount of equalization (and thus the CIM output level) is affected by various factors, including cable type, cable length, signal bandwidth, etc. Refer to the *Typical Operating Characteristics* “CIM Voltage vs. Cable Length” for typical values under specific conditions.

Loss-of-Signal ($\overline{\text{LOS}}$) Output

Loss-of-signal is indicated by the $\overline{\text{LOS}}$ output. A low level on $\overline{\text{LOS}}$ indicates that the equalizer input signal power has dropped below a threshold. The $\overline{\text{LOS}}$ output indicates a loss of signal. When the equalizer no longer detects a signal from the channel, the $\overline{\text{LOS}}$ output goes low. When there is sufficient input voltage to the channel (typically greater than 650mV), $\overline{\text{LOS}}$ is high. The $\overline{\text{LOS}}$ output is suitable for indicating problems with the transmission link caused by, for example, a broken cable, a defective driver, or a lost connection to the equalizer.

3.2Gbps Adaptive Equalizer and Cable Driver

Single-Ended Operation

For single-ended operation of the cable driver or equalizer, connect the unused input to ground through a series combination of a capacitor (of equal value to other AC-coupling capacitors) and a 50Ω resistor. Note that the MAX3800 is specified for differential operation.

Layout Considerations

The MAX3800's performance can be significantly affected by circuit-board layout and design. Use good high-frequency design techniques, including minimizing ground inductance and using fixed-impedance transmission lines for the high-frequency data signals. Power-supply decoupling capacitors should be placed as close as possible to VCC.

Pin Configuration

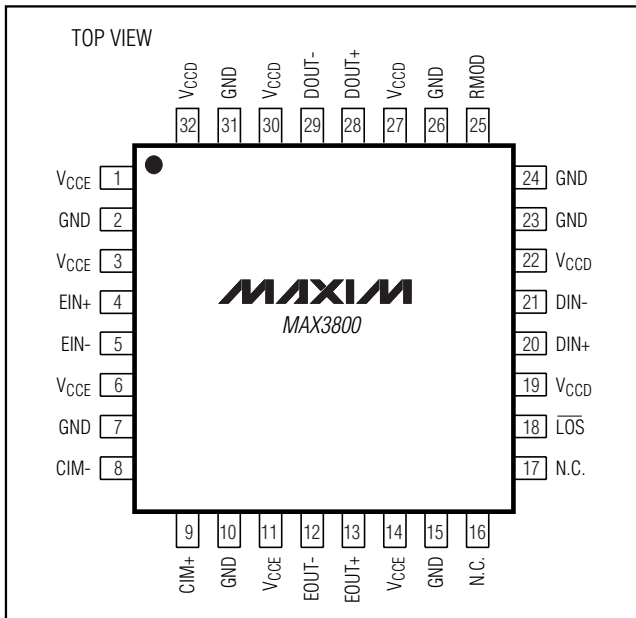

3.2Gbps Adaptive Equalizer and Cable Driver

Package Information

(The package drawing(s) in this data sheet may not reflect the most current specifications. For the latest package outline information go to www.maxim-ic.com/packages.)

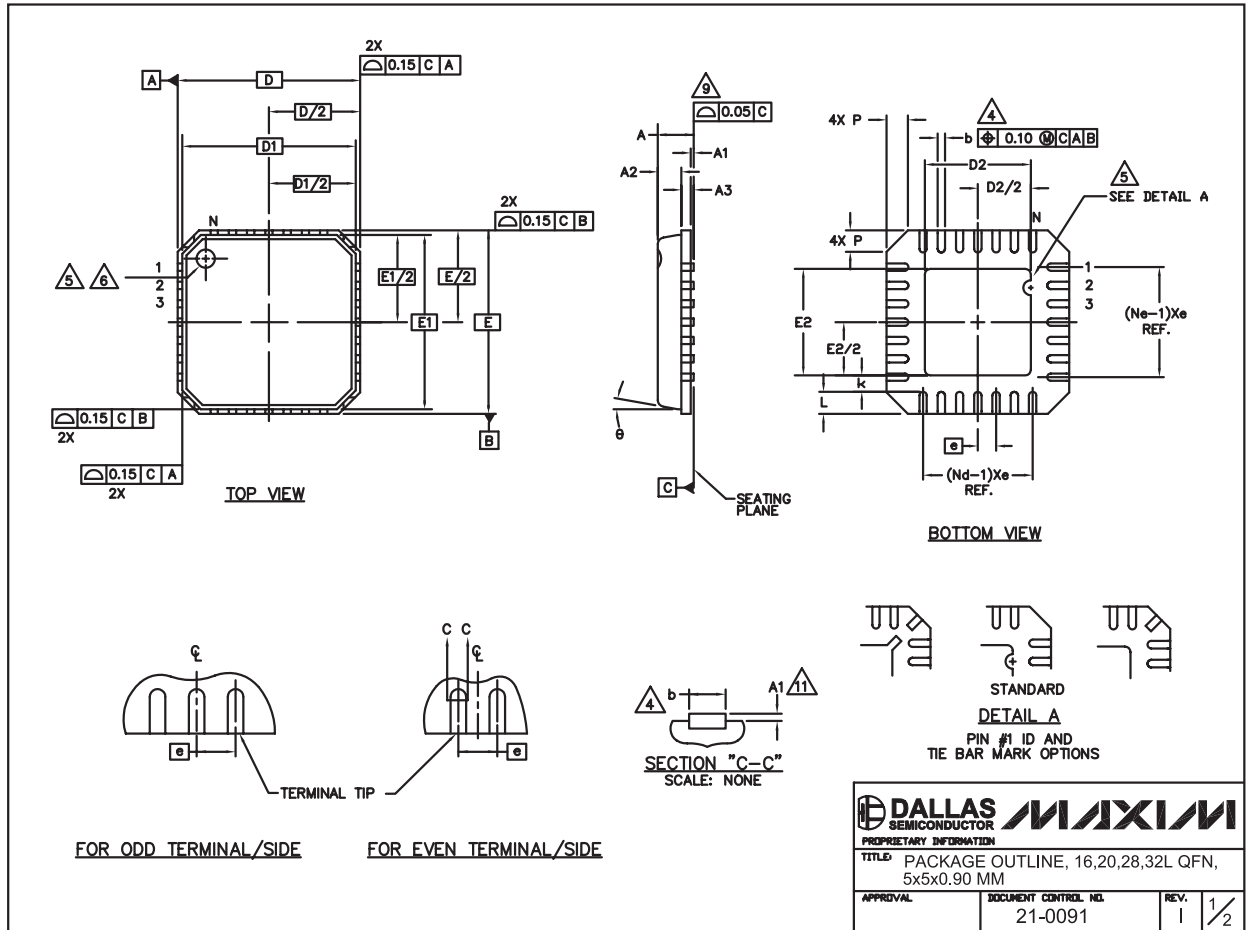

3.2Gbps Adaptive Equalizer and Cable Driver

MAX3800

Package Information (continued)

(The package drawing(s) in this data sheet may not reflect the most current specifications. For the latest package outline information go to www.maxim-ic.com/packages.)

COMMON DIMENSIONS												
PKG	16L 5x5			20L 5x5			28L 5x5			32L 5x5		
SYMBOL	MIN.	NOM.	MAX.	MIN.	NOM.	MAX.	MIN.	NOM.	MAX.	MIN.	NOM.	MAX.
A	0.80	0.90	1.00	0.80	0.90	1.00	0.80	0.90	1.00	0.80	0.90	1.00
A1	0.00	0.01	0.05	0.00	0.01	0.05	0.00	0.01	0.05	0.00	0.01	0.05
A2	0.00	0.65	1.00	0.00	0.65	1.00	0.00	0.65	1.00	0.00	0.65	1.00
A3	0.20 REF			0.20 REF			0.20 REF			0.20 REF		
b	0.28	0.33	0.40	0.23	0.28	0.35	0.18	0.23	0.30	0.18	0.23	0.30
D	4.90	5.00	5.10	4.90	5.00	5.10	4.90	5.00	5.10	4.90	5.00	5.10
D1	4.75 BSC			4.75 BSC			4.75 BSC			4.75 BSC		
E	4.90	5.00	5.10	4.90	5.00	5.10	4.90	5.00	5.10	4.90	5.00	5.10
E1	4.75 BSC			4.75 BSC			4.75 BSC			4.75 BSC		
e	0.80 BSC			0.65 BSC			0.50 BSC			0.50 BSC		
k	0.25	—	—	0.25	—	—	0.25	—	—	0.25	—	—
L	0.35	0.55	0.75	0.35	0.55	0.75	0.35	0.55	0.75	0.30	0.40	0.50
N	16			20			28			32		
ND	4			5			7			8		
NE	4			5			7			8		
P	0.00	0.42	0.60	0.00	0.42	0.60	0.00	0.42	0.60	0.00	0.42	0.60
ϕ	0"			12"			0"			12"		

EXPOSED PAD VARIATIONS						
PKG. CODES	D2			E2		
	MIN.	NOM.	MAX.	MIN.	NOM.	MAX.
G1655-3	2.95	3.10	3.25	2.95	3.10	3.25
G2055-1	2.55	2.70	2.85	2.55	2.70	2.85
G2055-2	2.95	3.10	3.25	2.95	3.10	3.25
G2855-1	2.55	2.70	2.85	2.55	2.70	2.85
G2855-2	2.95	3.10	3.25	2.95	3.10	3.25
G3255-1	2.95	3.10	3.25	2.95	3.10	3.25

NOTES:

- DIE THICKNESS ALLOWABLE IS 0.305mm MAXIMUM (.012 INCHES MAXIMUM)
- DIMENSIONING & TOLERANCES CONFORM TO ASME Y14.5M. - 1994.
- N IS THE NUMBER OF TERMINALS.
Nd IS THE NUMBER OF TERMINALS IN X-DIRECTION & Ne IS THE NUMBER OF TERMINALS IN Y-DIRECTION.
- DIMENSION b APPLIES TO PLATED TERMINAL AND IS MEASURED BETWEEN 0.20 AND 0.25mm FROM TERMINAL TIP.
- THE PIN #1 IDENTIFIER MUST BE EXISTED ON THE TOP SURFACE OF THE PACKAGE BY USING INDENTATION MARK OR INK/LASER MARKED. DETAILS OF PIN #1 IDENTIFIER IS OPTIONAL, BUT MUST BE LOCATED WITHIN ZONE INDICATED.
- EXACT SHAPE AND SIZE OF THIS FEATURE IS OPTIONAL.
- ALL DIMENSIONS ARE IN MILLIMETERS.
- PACKAGE WARPAGE MAX 0.05mm.
- APPLIED FOR EXPOSED PAD AND TERMINALS. EXCLUDE EMBEDDED PART OF EXPOSED PAD FROM MEASURING.
- MEETS JEDEC MO220; EXCEPT DIMENSION "b".
- APPLIED FOR EXPOSED PAD AND TERMINALS. EXCLUDE EMBEDDING PART OF EXPOSED PAD FROM MEASURING.
- THIS PACKAGE OUTLINE APPLIES TO ANVIL SINGULATION (STEPPED SIDES).

MAXIM	
<small>PROPRIETARY INFORMATION</small>	
TITLE: PACKAGE OUTLINE, 16,20,28,32L QFN, 5x5x0.90 MM	
APPROVAL	DOCUMENT CONTROL NO. 21-0091
REV. 1	

3.2Gbps Adaptive Equalizer and Cable Driver

Package Information (continued)

(The package drawing(s) in this data sheet may not reflect the most current specifications. For the latest package outline information go to www.maxim-ic.com/packages.)

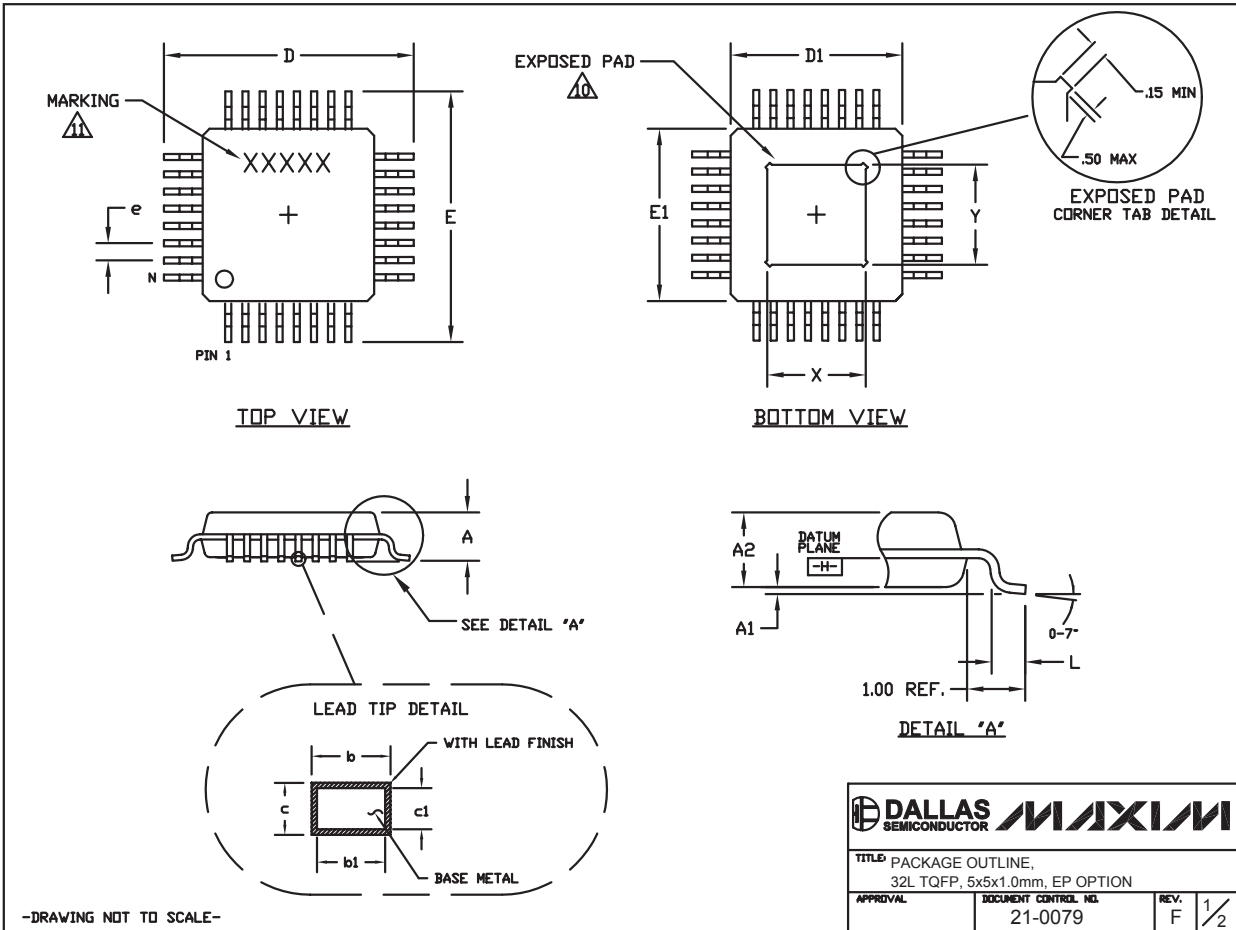

32L, TQFP, EPS

DALLAS SEMICONDUCTOR		MAXIM	
TITLE: PACKAGE OUTLINE, 32L TQFP, 5x5x1.0mm, EP OPTION			
APPROVAL	DOCUMENT CONTROL, NDL	REV.	1/2
	21-0079	F	

3.2Gbps Adaptive Equalizer and Cable Driver

MAX3800

Package Information (continued)

(The package drawing(s) in this data sheet may not reflect the most current specifications. For the latest package outline information go to www.maxim-ic.com/packages.)

NOTES:

1. ALL DIMENSIONING AND TOLERANCING CONFORM TO ANSI Y14.5-1982.
 2. DATUM PLANE \square IS LOCATED AT MOLD PARTING LINE AND COINCIDENT WITH LEAD, WHERE LEAD EXITS PLASTIC BODY AT BOTTOM OF PARTING LINE.
 3. DIMENSIONS D1 AND E1 DO NOT INCLUDE MOLD PROTRUSION. ALLOWABLE MOLD PROTRUSION IS 0.25 MM ON D1 AND E1 DIMENSIONS.
 4. THE TOP OF PACKAGE IS SMALLER THAN THE BOTTOM OF PACKAGE BY 0.15 MILLIMETERS.
 5. DIMENSION b DOES NOT INCLUDE DAMBAR PROTRUSION. ALLOWABLE DAMBAR PROTRUSION SHALL BE 0.08 MM TOTAL IN EXCESS OF THE b DIMENSION AT MAXIMUM MATERIAL CONDITION.
 6. ALL DIMENSIONS ARE IN MILLIMETERS.
 7. THIS OUTLINE CONFORMS TO JEDEC PUBLICATION 95, REGISTRATION MS-026.
 8. LEADS SHALL BE COPLANAR WITHIN .004 INCH.
 9. EXPOSED DIE PAD SHALL BE COPLANAR WITH BOTTOM OF PACKAGE WITHIN 2 MILS (.05 MM).
- \triangle DIMENSIONS X AND Y APPLY TO EXPOSED PAD (EP) VERSIONS ONLY. SEE INDIVIDUAL PRODUCT DATASHEET TO DETERMINE IF A PRODUCT USES EXPOSED PAD PACKAGE.
- \triangle MARKING IS FOR PACKAGE ORIENTATION REFERENCE ONLY.

COMMON DIMENSIONS		
DIMENSIONS IN MILLIMETERS		
JEDEC AAA-HD		
5x5x1.0 MM		
	MIN.	MAX.
A	\approx	1.20
A1	0.05	0.15
A2	0.95	1.05
D	6.80	7.20
D1	4.80	5.20
E	6.80	7.20
E1	4.80	5.20
L	0.45	0.75
N	32	
e	0.50 BSC.	
b	0.17	0.27
b1	0.17	0.23
c	0.09	0.20
c1	0.09	0.16
X	2.70	3.30
Y	2.70	3.30



TITLE: PACKAGE OUTLINE,
32L TQFP, 5x5x1.0mm, EP OPTION

APPROVAL	DOCUMENT CONTROL NO. 21-0079	REV. F	2/2
----------	---------------------------------	-----------	-----

-DRAWING NOT TO SCALE-

Maxim cannot assume responsibility for use of any circuitry other than circuitry entirely embodied in a Maxim product. No circuit patent licenses are implied. Maxim reserves the right to change the circuitry and specifications without notice at any time.

Maxim Integrated Products, 120 San Gabriel Drive, Sunnyvale, CA 94086 408-737-7600 13